

VARIABLE RANGE PUMP PROPORTIONER

HARDWARE



Features

Bronze and stainless steel material construction for performance and durability

Fresh, sea and brackish water compatible

Horizontal or vertical mounted position

Description

The SOLBERG® Variable Range Pump Proportioner is a foam solution proportioning device, designed to accurately proportion the foam concentrate into the water stream at both high and low system flow rates. The SOLBERG Variable Range Pump Proportioner is designed as an integral component of the SOLBERG foam pump proportioning system.

The SOLBERG Variable Range Pump Proportioner complies with NFPA 30, the Flammable and Combustible Liquids Code, Paragraph 16.5.1.6.2, which states that foam/water sprinkler systems are to provide foam solution to operating sprinklers with 4 sprinklers flowing. The SOLBERG Variable Range Pump Proportioner meets this Code requirement.

Application

The SOLBERG Variable Range Pump Proportioner is designed for systems where proportioning of foam concentrate will begin at low flow rates, but as additional sprinklers operate, the proportioner will automatically adjust for the changes in system flow rates and maintain accurate foam concentrate proportioning. Considering that the fire data shows that only 4 to 5 sprinklers will be necessary to control the flammable liquid fire risks, the SOLBERG Variable Pump Range Proportioner is the perfect solution for low system flow proportioning.

The primary applications for the SOLBERG Variable Range Pump Proportioner include closed-head foam/water sprinkler systems, protecting risks such as flammable and combustible liquid storage rooms, chemical processing, loading racks, aircraft hangars, and tank farm protection systems using foam chambers.

Specifications

The SOLBERG Variable Range Pump Proportioner is acceptable for use with SOLBERG foam concentrates, when



used as an integral component of a SOLBERG foam pump proportioning system. The SOLBERG Variable Range Pump Proportioner is designed to be installed as a between-the-flange proportioner, in standard 6.0" (152 mm) or 8.0" (203 mm) system piping. The foam concentrate inlet is 2.0" (50 mm) or 2.5" (64 mm) BSP female pipe size depending on the proportioner size selected.

The proportioner will accurately proportion foam concentrate at flow rates between 18 to 1,850 gpm (70 to 7000 lpm) for 6.0" (51 mm), and between 40 to 3,963 gpm (150 to 15000 lpm) for 8.0" (64 mm) sizes^[1].

^[1] The unit will operate with higher flows if the foam system can accept a higher pressure loss.

Solberg is a global company that is a one-stop resource for firefighting foam concentrates and custom-designed foam suppression systems hardware, offering both traditional and innovative firefighting foam technology. www.solbergfoam.com

The SOLBERG Variable Range Pump Proportioner is manufactured using a bronze body and cone shaped piston, stainless steel spring, and stainless steel foam metering orifice. The SOLBERG Variable Range Pump Proportioner is to be installed with a minimum of 5 pipe diameters (30.0" (762 mm)) of straight pipe both upstream and downstream of the proportioner. The proportioner body is

cast with a directional flow arrow on the proportioner body indicating the proper orientation of installation.

The SOLBERG Variable Range Pump Proportioner operation in closed-head sprinkler systems is as follows:

Under static, no flow conditions in the water supply piping, the water and foam concentrate pressures are equal. During a fire situation as sprinklers

begin to open, the foam concentrate is injected into the water supply through the foam concentrate metering orifice at the proper listed solution rate.

As more sprinklers begin to operate, the change in foam-water solution demand is automatically adjusted for by the SOLBERG Variable Range Pump Proportioner, by injecting a carefully calibrated increased quantity of foam concentrate into the piping.

Dimensional Information

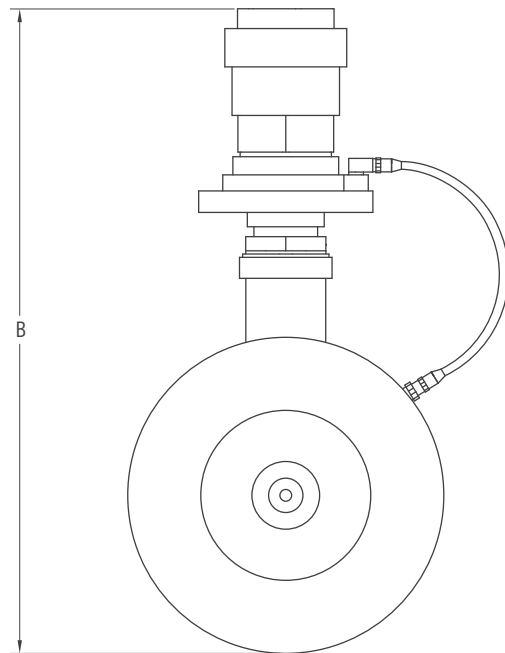
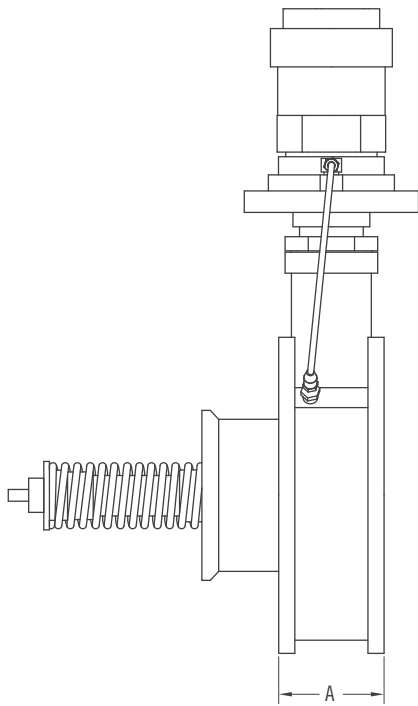



Performance Information

Model SVRPP	6.0" (152 mm)	8.0" (203 mm)
Size	DN 150	DN 200
Foam Inlet Female	R 2.0" (50 mm)	R 2.5" (64 mm)
Flow Range	18-1850 gpm (70-7000 lpm)	40-3963 gpm (150-15000 lpm)
Connection Water	6.0" between flange, DIN PN-16	8.0" between flange, DIN PN-16
Connection Foam	2.0" (50 mm) Female BSP	2.5" (64 mm) Female BSP
Proportioning Rate (pre-calibrated)	SOLBERG Foam Concentrates	SOLBERG Foam Concentrates
Inlet Pressure (max)	232 psi (16 bar)	232 psi (16 bar)
Inlet Pressure (min)	73 psi (5 bar)	73 psi (5 bar)
Pipe Length Upstream	30.0" (762 mm)	40.0" (1000 mm)
Pipe Length Downstream	30.0" (762 mm)	40.0" (1000 mm)
Flange Type	DIN PN16	DIN PN16
Between Flange Proportions (Dimension A)	2.75" (69 mm)	3.5" (88 mm)
Height (Dimension B)	13.0" (330 mm)	17.0" (430 mm)

Note: Over pressurization of 14.5 psi (1 bar) minimum is required on the foam concentrate side.

Ordering Information

PART NO.	DESCRIPTION	SHIPPING WEIGHT	
		lb	kg
RATIO CONTROLLERS / VARIABLE RANGE			
30202	Ratio Controller - Variable Range Pump Proportioner, Model SVRPP 6.0" (152 mm)	35	16
30203	Ratio Controller - Variable Range Pump Proportioner, Model SVRPP 8.0" (203 mm)	106	48



SOLBERGFOAM.COM

FORM NUMBER F-2012012
 COPYRIGHT © 2011. ALL RIGHTS RESERVED.
 SOLBERG®, ARCTIC™ AND ATC™ ARE TRADEMARKS
 OF THE SOLBERG COMPANY OR ITS AFFILIATES.

AMERICAS
 THE SOLBERG COMPANY
 1520 Brookfield Avenue
 Green Bay, WI 54313
 USA
 Tel: +1 920 593 9445

EMEA
 SOLBERG SCANDINAVIAN AS
 Radøyvegen 721 - Olsvollstranda
 N-5938 Sæbøvågen
 Norway
 Tel: +47 56 34 97 00

ASIA-PACIFIC
 SOLBERG ASIA PACIFIC PTY LTD
 3 Charles Street
 St. Marys NSW 2760
 Australia
 Tel: +61 2 9673 5300